

Key:

- A. 10mm (.395 in.) male snap to ground floor mats.
- B. Molded in black thermoplastic elastomer.
- C. High flex strand copper, 20 gauge, with PVC insulated jacket.
09813 - black insulation
09814 - green insulation with yellow stripe
OD = .107"
- D. Ring terminal, .200" ID, (#10).
- E. Extra ring terminal provided for customizing length.
- F. Item 09813 has a one megohm resistor between the snap and ground. Item 09814 has no resistor between the snap and ground.
- G. Brass crimp secures conductors and provides stress relief.
- H. Desco logo molded onto cap on top of shroud. Arrow points to month of manufacture (12:00 = December), numerals indicate the year (03=2003).
- I. Date coded to show month and year of manufacture. Arrow points to month of manufacture (12:00 = December), numerals indicate the year (03=2003).
- J. 6-32 x 1/4" flat head screw and washer allow floor mat ground to be bolted to mat.

For Grounding ESD Protective Floor Mats

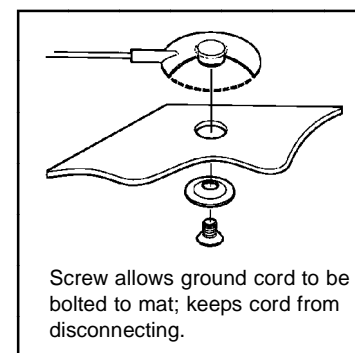
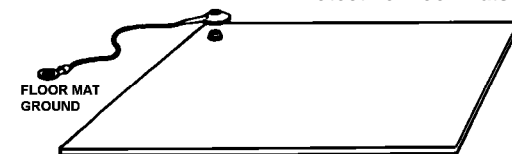

ITEM	DESCRIPTION
09813	One Megohm Resistor to Mat - Black Wire
09814	No Resistor - Green Wire with Yellow Stripe

GROUND CORD, FLOOR MAT, THREADED 10MM SNAP STUD



DESCO WEST: 3651 WALNUT AVE., CHINO, CA 91710 WEB SITE: www.desco.com
 PHONE (909) 627-8178 FAX (909) 627-7449
 DESCO EAST: 90 HUDSON RD, CANTON, MA 02021-1407
 PHONE (781) 821-8370 FAX (781) 575-0172

DRAWING NUMBER
09814

DATE:
07/04